



EQUALIZER
S Y S T E M S

Electric & Hydraulic Lifting Systems

Elkhart, Indiana

800-846-9659

www.equalizersystems.com

AutoLevel® AutoAir™

Operation,
Troubleshooting
&
Warranty Manual

EL-PAC 1 & 2

!!!! Warning: Read entire instructions and all precautions prior to installing, using or troubleshooting this equipment.

CONTENTS

General Notes for El Pac 1 & 2	2
Installation of El Pac 1 on <u>New</u> Style Single Speed Bulldog Jacks	3
Installation of El Pac 1 on Old Style Single Speed Bulldog Jacks	5
Installation of El Pac 1 on Single Speed Fulton Jacks	6
Installation of El Pac 1 on Two Speed Bulldog Jacks with 4" x 4" Gear Reduction Box	7
Installation of El Pac 2 on Binkley Two Speed Jacks Drivers Side	9
Installation of El Pac 2 on Binkley Two Speed Jacks Passengers Side	11
Power Supply and Switchgear Connections for El Pac 1 & 2	12
Basic Troubleshooting	13
Parts List	14
Warranty	15
Diagrams	Appendix

General Notes for El Pac 1 and El Pac 2 Electric Lifting Systems

The recommended maximum floor lengths are guidelines. However, the installer must use judgment based on each individual trailer. Items to consider: aluminum or steel construction; width of trailer; length of living quarter; materials used in the living quarter (hardwood floors, solid surface countertops, etc.); water and holding tanks; tool boxes; tack; etc. If the trailer is on the edge of our length recommendations below, please weigh the trailer. The tongue weight of the trailer must be less than the maximum lift capacity of the product.

Questions? Call Equalizer Systems at (800) 846-9659 for technical assistance.

The **El Pac 1** gearbox has a specific gear ratio and a maximum lifting capacity of 5,000 lbs. It is recommended that the length of the trailer should be no greater than 28 feet of floor length.

The **El Pac 1** must be installed on a Bulldog (Cequent) Single Speed jackleg, Fulton Single Speed jackleg (this leg should have a stamp or decal that says "gear driven adaptable"), or 2-speed Bulldog jacklegs. The El Pac 1 is not compatible with any other jackleg.

The **El Pac 2** gearbox has a specific gear ratio and a maximum lifting capacity of 6,500 lbs. It is recommended that the length of the trailer should be no greater than 32 feet of floor length.

The **El Pac 2** must be installed on Binkley 2-speed jacklegs. The El Pac 2 is not compatible with any other jackleg.

AVOID HEADACHES!

You must determine the manufacturer of the jackleg installed on your trailer prior to selecting the appropriate El Pac for your application.

Note that the El Pac 1 & 2 have specific gear ratios and specific jacklegs they may be installed with. You must correctly identify the OEM equipment on your unit. Please note that decals or stickers alone are often insufficient to determine the OEM of your jackleg(s).

INSTALLATION of EL PAC 1

('New Style' Single Speed Bulldog Jacks)

The Cequent Corporation has made engineering changes to some of their Bulldog product line. These changes affect the mounting of an **EL Pac 1** on these legs. Bulldog no longer utilizes collars on the outside of the jackleg where the Equalizer Systems U-bolts are mounted.

The **EL PAC 1** is designed to mount on either side of the jack leg; HOWEVER, the preferred mounting would be on the passenger side of the jack leg if space permits. This enables you to leave the factory crank rod in place as a manual back-up. If mounting on the driver's side of the trailer, the factory crank and handle attaches to the **EL Pac 1** override output shaft. When attaching your factory crankshaft to the override output shaft, use the supplied nylon bushing (part # 1961E). When properly mounted on the passenger side of the jack leg, this unit has a maximum lifting capacity of 5000 lbs. of jack weight.

Warning: Remove the factory crank handle from the end of the crank rod. Damage may occur to the trailer or persons if the handle is left in place.

Installation

1. The new style Bulldog jackleg no longer utilizes bearing bosses on the outside of the jackleg where the Equalizer Systems U-bolts and bracket were originally installed.
2. Align the bracket as usual (refer to the **EL Pac1** 'old style' mounting instructions). The shaft must be cut 1" (measured from the jackleg to the end of the shaft).
3. Use the two supplied U-bolts. Attach mounting bracket so that the U-bolts wrap around the shaft on the jackleg and come through the front of the bracket. Align the bracket correctly (square to the jackleg and centered on the shaft). Attach with supplied nuts. Do not over-tighten - these U-bolts will be removed.

4. Slide **EL Pac 1** over jack shaft. Attach the **EL Pac 1** to the bracket using the (4) supplied $\frac{1}{4}$ " x $\frac{3}{4}$ " bolts and lock washers.
5. Securely weld the **EL Pac 1** bracket in place on the front of the jackleg.
6. **Remove the U-bolts and discard.**
7. Drill a hole through the jack shaft using the output shaft of the **EL Pac 1** as a guide. Use the supplied $\frac{5}{16}$ " x 2" bolt and nylock nut to secure the output shaft to the jack shaft.
8. Mount switchgear in desired location.
9. Refer to the Power Supply and Switchgear installation instructions.

'New Style' Single Speed Bulldog Jacks

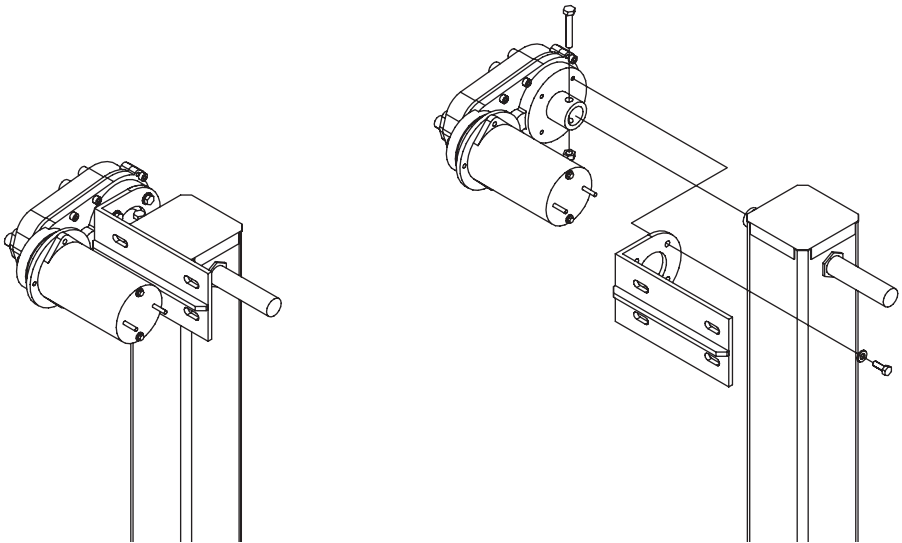

INSTALLATION of EL PAC 1

('Old Style' Single Speed Bulldog & Fulton Jacks)

The **El Pac 1** must be installed on the “old style” Bulldog Single Speed jackleg & Fulton Single Speed jackleg (this leg should have a stamp or decal that says “gear driven adaptable”). Any other jackleg is NOT compatible with the El Pac1.

Once again, the **EL PAC 1** is designed to mount on either side of the jack leg; HOWEVER, the preferred mounting would be on the passenger side of the jack leg if space permits. This enables you to leave the factory crank rod in place as a manual back-up. If mounting on the driver's side of the trailer, the factory crank and handle attaches to the **El Pac 1** override output shaft. When attaching your factory crank shaft to the override output shaft, use the supplied nylon bushing (part # 1961E). When properly mounted on the passenger side of the jack leg, this unit has a maximum lifting capacity of 5000 lbs. of jack weight.

Warning: Remove the factory crank handle from the end of the crank rod. Damage may occur to the trailer or persons if the handle is left in place.

Installation of El Pac 1 on Bulldog 'Old Style'

1. Decide which side of the jack leg the **El Pac 1** will mount. This unit requires 7” of width clearance from the jack leg.
2. Cut off the shaft so that 1¹/₈” of the shaft remains on the jack leg. Measure this from the outer edge of the boss to the end of the shaft.
3. Use the two supplied U-bolts. Attach mounting bracket so that the U-bolts wrap around the bearing bosses on the jackleg and come through the front of the bracket. Align the bracket correctly (square to the jackleg and centered on the shaft). Attach with supplied nuts. Do not tighten yet.
4. Slide El Pac 1 over jack shaft. Attach the EL Pac 1 to the bracket using the (4) supplied ¼” x ¾” bolts and lock washers.

5. Tighten U-bolts securely to the bracket. A tack weld may be used as reinforcement, if desired.
6. Drill a hole through the jack shaft using the output shaft of the El Pac 1 as a guide. Use the supplied 5/16" x 2" bolt and nylock nut to secure the output shaft to the jack shaft.
7. Mount switchgear in desired location.
8. Refer to the Power Supply and Switchgear installation instructions.

Installation of El Pac 1 on Fulton'

1. The installation of an **El Pac 1** on a Fulton jack is accomplished by welding the bracket to the jackleg, as in the installation for a "New Style" Bulldog jack. Note that the Fulton has a smaller shaft than the Bulldog. In this case, use the supplied nylon bushing (part # 1961E) around the shaft prior to sliding the **El Pac 1** in place.

'Old Style' Single Speed Bulldog & Fulton Jacks

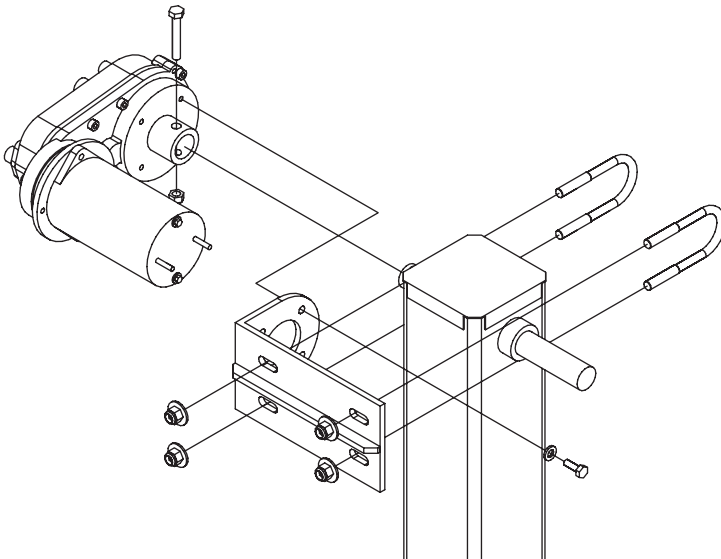

INSTALLATION of EL PAC 1

(Two Speed Bulldog Jacks with 4"x4" gear Reduction Box)

Single Leg Application – The **El Pac 1** must be installed on the passenger side of a single Bulldog two-speed jack with the 4"x 4" gear reduction box. This enables utilization of the existing crank shaft and handle as a manual override. When properly mounted, this unit has a maximum lifting capacity of 5000 lbs. of jack weight.

Dual Leg Application – The **El Pac 1** must be installed on the passenger side of the passenger side jack leg with Bulldog two-speed jacks with the 4"x 4" gear reduction box in a dual leg application. When properly mounted, this unit has a maximum lifting capacity of 5000 lbs. of jack weight.

The El Pac 1 must be installed on the passenger side of the Bulldog two-speed jack.

The Bulldog two-speed jack leg must be in the high [hard to turn] gear prior to installation of the El Pac 1.

Warning: Remove the factory crank handle from the end of the crank rod. Damage may occur to the trailer or persons if the handle is left in place.

Failure to follow the above directives will void your warranty

Installation

Again, you must leave jack leg in the 'hard to turn' gear; Do not utilize the first speed. Failure to have jack leg in the high gear will void warranty.

1. The El Pac 1 must be installed on the passenger side of the Bulldog two speed jack with the 4"x 4" gear reduction box. See the drawings below. This unit requires 6" of width clearance from the jack leg.

2. Cut jack shaft (if needed) so that 1 $\frac{1}{8}$ " of the shaft remains from the end of the shaft to the jack body.
3. Attach the EL Pac 1 to the bracket using the (4) supplied $\frac{1}{4}$ " x $\frac{3}{4}$ " bolts and lock washers.
4. Slide the El Pac 1 gearbox over shaft. Align the bracket correctly (square to the jackleg and centered on the shaft).
5. Securely weld the bracket onto the front of the jack to hold the bracket in place. For this application, the U-bolts will not be used.
6. Drill a hole through the jack shaft using the output shaft of the El Pac 1 as a guide. Use the supplied 5/16" x 2" bolt and nylock nut to secure the output shaft to the jack shaft.
7. Mount switchgear in desired location.
8. Refer to the Power Supply and Switchgear installation instructions.

Two-Speed Bulldog Jacks with 4" x 4" Gear Reduction Box
--

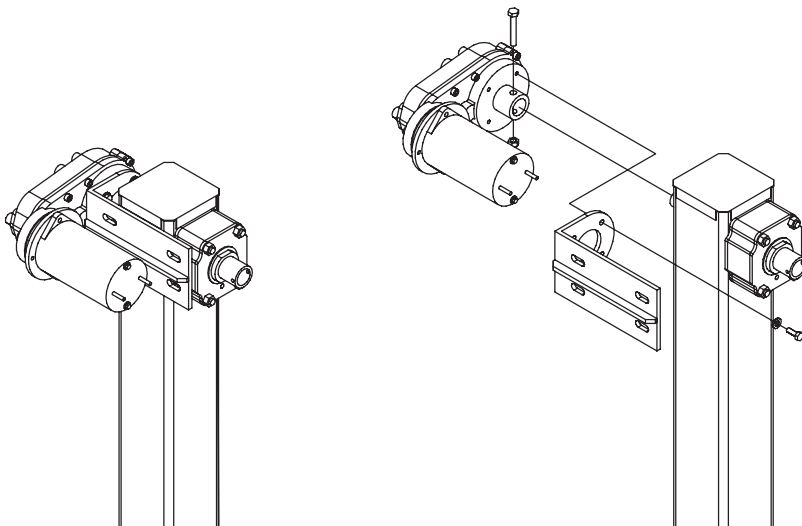

INSTALLATION of EL PAC 2

(Binkley Two-Speed Jacks)

The **El Pac 2** is designed to mount on either side of the Binkley 2-speed jack leg. The suggested mounting style is on the drivers side of the existing jack leg. This will allow the factory crank and handle to attach to the **EL Pac 2** override output shaft. It is recommended to remove the wires from the gear box motor prior to hand cranking to allow easier hand cranking. When attaching your factory crank shaft to the override output shaft, use the supplied nylon bushing (part # 1961E). The **El Pac 2** has a maximum lifting capacity of 6,500 lbs. of front jack weight.

Warning: Remove the factory crank handle from the end of the crank rod. Damage may occur to the trailer or persons if the handle is left in place.

Installation on Drivers Side of Jack Leg

1. Decide which side of the jack leg the **El Pac 2** will mount. This unit requires 7" of width clearance from the Binkley gearbox for mounting.
2. **Pull crank rod out into low gear (easy to turn).** Cut jack shaft (if needed) so that 1 $\frac{1}{8}$ " of the shaft remains.
3. Slide the mounting bracket over the shaft boss and tap into place. Secure the setscrews. It may be necessary to tack weld the bracket in place to keep the boss on the Binkley gearbox from rotating during operation.
4. Slide **El Pac 2** gearbox onto shaft.
5. Attach the **El Pac 2** to the bracket using the (4) supplied $\frac{1}{4}$ "x $\frac{3}{4}$ " bolts and lock washers.
6. Drill a hole through the jack shaft using the output shaft of the **El Pac 2** as a guide. Use the supplied 5/16" x 2" bolt and nylock nut to secure the output shaft to the jack shaft.

- 7. Mount switchgear in desired location.
- 8. Refer to the Power Supply and Switchgear installation instructions.

Binkley Two-Speed Jacks - Drivers side installation

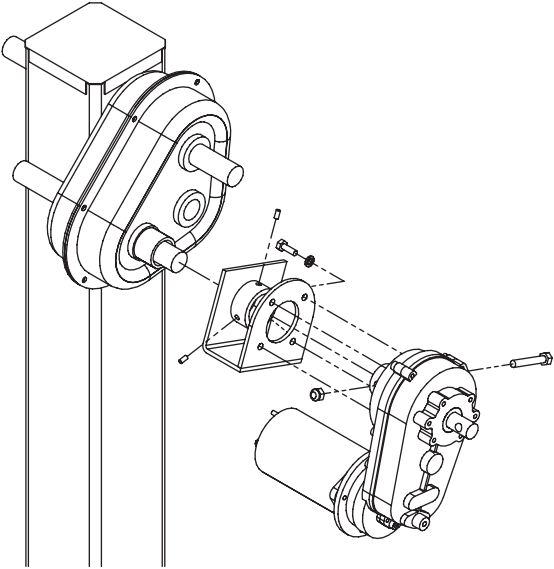

Installation on Passengers Side of Jack Leg

1. Again, the suggested (and preferred) mounting style is on the drivers' side of the existing jack leg. However, it may be necessary to mount your **EI Pac 2** on the passenger side of your jack leg due to space limitations. There must be 2.0" of shaft extending past the jack leg.
2. Slide the mounting bracket over the lower shaft on the passenger side of the Binkley gearbox. **Pull crank rod out into low gear (easy to turn)**.
3. Slide the **EI Pac 2** gearbox onto the shaft. Attach the **EI Pac 2** gearbox to the mounting bracket and slide the bracket flush against the Binkley jack leg.
4. Securely weld the bracket to the leg. Ensure the gearbox and bracket are straight.
5. Drill a hole through the jack shaft using the output shaft of the **EI Pac 2** as a guide. Use the supplied 5/16" x 2" bolt and nylock nut to secure the output shaft to the jack shaft.

Binkley Two-Speed Jacks - Passenger side installation

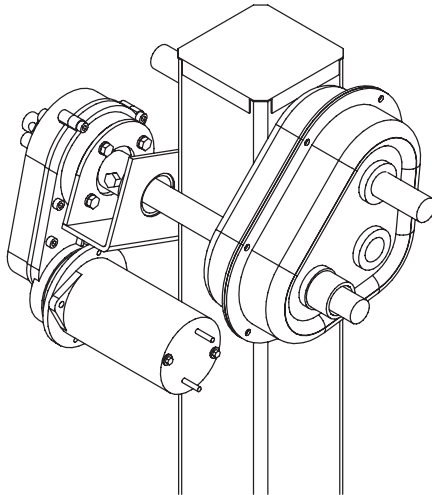

POWER SUPPLY AND SWITCHGEAR CONNECTIONS FOR EL PAC 1 & 2

Make the connection of the +12 volt cable to the battery the very last connection. Check all other connections and have the switchgear mounted and connected to the El Pac prior to applying power

Your El Pac system comes with an 80-ampere auto-reset circuit breaker (2ea. 40 ampere breakers in parallel configuration). Do not install other fuses or circuit breakers.

1. Mount the switchgear in the desired location, being aware of the provided cable lengths. Mount the switch gear in a location that provides some protection from the elements. The switchgear box is *water-resistant*, not *water-proof*.

2. Route the Red and Black #6 AWG wire from the switchgear to the battery box. Use the supplied plastic split loom to protect the wires. NOTE: *If the battery is located beyond the front bulkhead of the trailer, #4 AWG wires may be required to provide enough current for your El Pac to operate properly.* Cut the black wire (and loom) to length and install the supplied crimp ring terminal. Attach the black to the -12 volt battery terminal. Do not connect the +12 volt cable.

3. Next, route the Green and White #6 AWG wires from the switchgear to the El Pac Gearbox motor. Use the supplied plastic split loom to protect the wires. Cut both wires to length and install the supplied crimp ring terminals.

4. Attach the Green wire to the A2+ and the White wire to the A1- posts on the motor. NOTE: *The switch may appear to operate backwards, depending on which side of the OEM jack leg your El Pac is mounted. If this is the case, switch the Green to A1- and the White to A2+ posts.*

5. Secure all wire looms to the trailer. Be aware of heat and pinch points.

6. Affix the 80-ampere breaker assembly to the battery box or other suitable location. Be aware of the length of the +12 volt pigtail attached to the breaker assembly.

7. Attach the Red #6 AWG wire from the switchgear to the 'AUX' post on the breaker assembly using the supplied crimp ring terminal. This 'AUX' post will have two nuts present and is diagonal from the +12 volt battery pigtail. Install the crimp ring and use the first nut as a jamb nut to hold the wire securely to the assembly.

8. Finally, attach the RED #6 AWG pigtail from the 'BATT' post on the breaker assembly to the +12 volt terminal on the battery.

Rotary Switch Wiring for E1 Pac

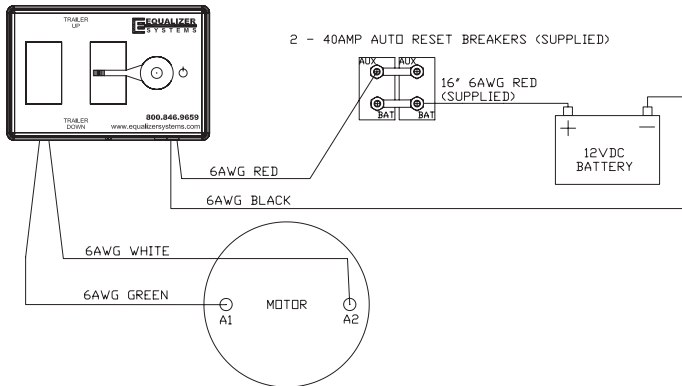

TROUBLESHOOTING

“When I run the motor, it stops or cuts out”

- Low battery voltage. Charge your batteries.
- System may be overloaded and/or tripping the circuit breaker connected to switchgear.

“The motor runs, but is ‘clutching out’ when trying to lift the trailer”

- The unit is overloaded. The load may exceed the maximum lifting capacity. Weigh your trailer.
- Two speed jack in improper gear.
- The clutch may be set to low. Call Equalizer at (800) 846-9659 for technical assistance.

“The motor runs, but the shaft does not turn”

- Pinion gear may be stripped or has come off the motor. Call Equalizer at (800) 846-9659 for technical assistance.

PARTS LIST

# 8148	El Pac 1 - Complete System
# 8165	El Pac 2 - Complete System
# 6677	El Pac Switch and Harness Assembly - Complete Assembly

Part # 6677 includes:

# 1553	Switch Gear Box - Housing Only
# 1511	Rotary Switch
# 1554	Plastic Plug

Other El Pac 1 & 2 Parts:

# 2125 (2ea)	40 Amp Thermal Circuit Breaker
# 1502	Motor - Spline Shaft
# 1679	Motor Pinion 12 tooth x 24
# 1929	Fulton Mount Bracket
# 2372	El Pac 2B Bracket
# 2530	El Pac 1B Bracket
# 1961E	Nylon Override Output Shaft Bushing

EQUALIZER SYSTEMS LIMITED WARRANTY POLICY

RV or Vehicle Manufacturer Installed Systems or Components:

1. Only warranty claims with prior written or verbal authorization from Equalizer Systems will be recognized, all other claims will be denied.
2. Equalizer Systems warrants slide out and leveling system components for a period of three years from the date of original sale of the vehicle. This warranty covers defects in material and workmanship only. Equalizer Systems is not liable for any damage due to abuse, neglect, misuse, negligence, misapplication, error of operation, accidental or purposeful damage or damage due to an “act of God” such as, wind or rain damage, flood, lightning or other natural occurrence of the like. Equalizer Systems limited warranty is applicable to the Equalizer Systems components only and does not apply to the vehicle, apparatus or property to which it is attached. Warranty parts will be shipped at no charge if the repair is authorized by an Equalizer Systems representative. Purchased components used in authorized warranty repairs will be reimbursed at the original purchase price.
3. Labor and freight expenses due to warrantable parts defects or workmanship will be reimbursed for a period of one year from the date of original sale of the vehicle. Freight expenses will either be prepaid by Equalizer Systems or reimbursed at the UPS Ground rate only. Any additional shipping charges or requirements are the obligation of the vehicle owner or service center performing the warranty repair. The owner or service center’s obligation may include overseas shipping charges, border fees, brokerage fees and any other additional fee of the like.
4. Warranty labor will be reimbursed only for claims that have prior written or verbal authorization from an Equalizer Systems representative. Warranty labor compensation is required to correspond with the “Warranty Parts Replacement Time Guideline” published by Equalizer Systems. Any warranty repair not listed on

this guideline will require prior authorization from an Equalizer Systems representative. A reasonable time allowance will be determined by the Equalizer Systems representative. Any warranty repair that is not listed on this guideline that is performed without prior authorization will be denied without exception. Time associated with learning about the repair or excessive diagnostic and installation time will not be reimbursed. Warranty labor will be reimbursed at the authorized service center's published shop rate if the rate is reasonable for that region. Overtime labor will not be reimbursed without exception.

5. Labor, parts and freight credit (if applicable) will be sent after the parts are tested and the warranty claim is validated. Returned parts that are found to be in normal operating condition are not warrantable and will be charged to the owner or service center. Equalizer Systems reserves the right to charge back the service center for labor claim payments previously submitted if the installation of the warranted part is found to be inadequate at a later date.

6. Claims will be denied if the date submitted is greater than 30 days from the repair date.

7. Prior authorization is required before parts may be sent back to Equalizer Systems. A Return Authorization Number required for items to be accepted.

8. Complete systems are not warranted unless authorized by an Equalizer Systems representative. There are absolutely no exceptions to this clause.

9. This warranty begins upon the original sale date of the vehicle and is transferable, with limitation, to subsequent owners upon furnishing the original sale date of the vehicle and proof of purchase. Only the remainder of the three year parts warranty is applicable. Warranty labor and freight are only applicable to original owner of the vehicle.

10. Equalizer Systems is not liable for loss of time, manufacturing costs, labor material, loss of profits, direct or indirect damages incurred by the vehicle manufacturer.

11. Excessive warranty labor resulting from inadequate access to the Equalizer Systems product will not be reimbursed.

12. Equalizer Systems will not pay a markup on warranty parts unless required by law.

13. Travel expenses, hotel, telephone, fuel or any other expenses of the like are not covered under warranty.

Replacement Parts:

1. Replacement parts are warranted under the same guidelines listed above for the remainder of the original warranty or 90 days, whichever is longer. Proof of warranty repair date and original vehicle purchase date are required.

2. No additional warranties, expressed or implied, are authorized by Equalizer Systems

3. This warranty voids all previous issues. Questions concerning this warranty should be directed to:

Equalizer Systems	(800) 846-9659
P.O. Box 668	(574) 264-3437
Elkhart, IN 46515	(574) 266-6083 fax

Equalizer Systems
P.O Box 668, 55169 CR 3 North
Elkhart, IN 46515
(800) 846-9659