



1-800-846-9659

www.equalizersystems.com

Installation and Operation Guide

January 2011

Single Leg AM / CM – 20, 24 and 30

Installation

Tools Required for Installation

- Ratchet, Sockets and Wrench Set
- Wire Cutters / Crimpers
- Electric Drill and Bits
- Screw Gun Bit
- Welding Equipment (if welding jack in place)

Additional Parts Needed for Installation

- #4 gauge Power wire (to connect battery +12V Positive to the Pump)
- #4 gauge Ground wire (to connect battery -12V Ground to Pump)
- #4 gauge Ring Terminals
- Loom Clips (to secure Switch and Harness to the Trailer)
- Self tapping screws or pop rivets (to secure loom clips)
- Wire Ties

Jack

Your AM / CM Jack may have been provided with a mounting flange or bracket (depending on the mounting option ordered for your system). When Bolting the Jack to the trailer we recommend using **Grade 8** bolts. Welding the Jack in place requires sound welding practices.

The Jack should be mounted so that when the trailer is level (while mounted to the tow vehicle) there is a **Range of 10 inches Minimum of Ground Clearance**. This is usually achieved by mounting the jack so that the foot is slightly below the bottom edge of trailer. **The Bottom of the Footpad Should Not be Lower than any other Item Mounted on the Trailer.**

Switch Harness and Hydraulic Lines

The AM/CM Jack has been shipped with all necessary Switchgear, Harnesses and Hydraulic Lines. These items are specifically Engineered to operate your System and should not be altered in any Manner. Modification of any Factory Supplied Item may result in the Denial of All Warranty Claims.

Switchgear

The Unit may have been provided with a key switch in the switchgear box (depending on the option ordered). If unit is not supplied with a key switch, the +12v battery lead must be fed through a power disconnect switch to fully isolate the system during travel or inactivity. Minimum switch rating must be 100 ampere DC. Switchgear is plugged into the system harness through a weather resistant connector (shown in Fig.1)



Fig.1- Weather Resistant Connector

Battery Connections for MTE Style Pump with Manual Override

Pumps #'s 2142, 2390, 2532

Battery Connections

Battery Lead (+12volts): Attach a # 4 gauge wire between the Positive (+12V) terminal on the Battery and the Large Post on the Solenoid opposite the Black Motor Wire on the Solenoid. If circuit protection is required, Install an 80 amp (minimum) Circuit Breaker.

Battery / Pump Ground (-12volts): Attach a # 4 gauge wire between the Negative (-12v) terminal on the Battery and the Ground Stud located directly in front of the motor. It is not acceptable to allow the Jack mounting bolts or the weld to be the sole grounding connection.

If Equipped: Pump #'s 3040, 3041 see Fig. 2

Attached a # 6 gauge wire between the Positive (+12V) Terminal on the Battery and the Plus (+) Terminal on the Contactor. Attach #6 Gauge wire between Battery Negative (-) and the Pump Ground Stud.

Fig. # 2: Pictured
Pump #'s, 3040, 3041



Reservoir Breather Cap for MTE Style Pump with Manual Override

With the jack installed in the vertical position, remove the Flush Mounted Fill Plug from the top of the reservoir and discard. Replace with 6-sided Breather Cap. Failure to do so will cause the jack to operate erratically.

Operation

To raise and lower the jack, simply push and hold the rocker switch in the up or down position. The jack will hold a position by releasing the switch at any time. There is no need to take the weight off the jack when storing the trailer, as the positive check valves in the system will not allow the jack to bleed down.

*Note: When the jack is fully retracted, the fluid level in the reservoir should be approximately one inch below the fill cap. If fluid needs to be added, use Dexron III automatic transmission fluid (the same as used for a GM automobile).

* Caution *

The keyed switch must be in the off position and the key must be removed when the jack is not in use and/or when the trailer is in transit. If unit is not supplied with a keyed switch, the +12v battery lead must be fed through a power disconnect switch to fully isolate the system during inactivity or travel. The minimum switch rating must be 100 ampere DC.

With any hydraulic application, holding any position on a cylinder must be done with safety in mind. Failure in the system may cause the jack to retract or extend on its own. When working under or near the trailer, always use jack stand of appropriate rating to support the weight of the trailer.

Manual Override – Hand Pump - Pump # 2142

The following procedure gives step-by-step instructions on how to operate the manual override to either extend or retract the jacks.

Your AM / CM series Single Leg Jack is available with a Manual Override, depending on the specific unit ordered. ***If your unit is equipped with the Override Hand Pump, it is operated as follows:***

To **Extend** your jack:

1. Install a handle in the hand pump. Pump the handle to extend the jack. You may have to pump 10-20 times before you build enough pressure and the jack begins to extend.

To **Retract** your jack:

1. Locate the red knurled knob on the directional valve. Pull it out and turn ½ turn. The knob will remain in the “out” position. Do not use anything other than your fingers to manually shift the directional valve.
2. Install a handle in the hand pump. Pump the handle to retract the jack. You may have to pump 10-20 times before you build enough pressure and the jack begins to retract. Return the directional valve to the normal position. Reinstall black plastic cap on motor.

Caution: Following manual override operation, failure to return all valves to normal position may result in one or more jacks drifting down from their retracted (stowed) position. For directional valves, rotate the red knob until it “snaps” back to the normal position.

Manual Override – Output Shaft

If your Unit is not Equipped with the Override Hand Pump, it is Operated as Follows: Pump #'s 2390, 2532, 3041, 3042

1/4 " (6mm) Allen Drive Hex Key or 7/16 " (11mm) Hex Head Socket

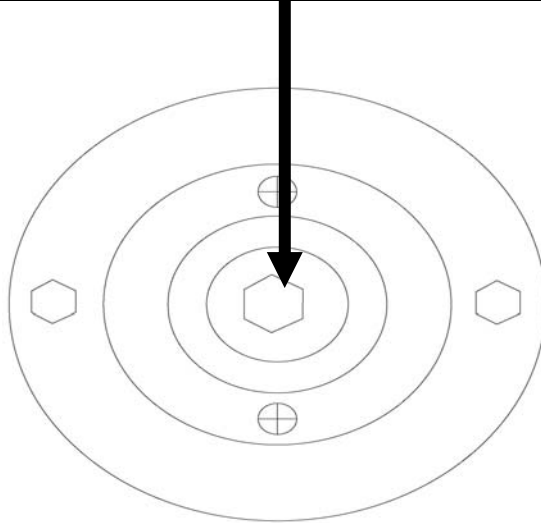

Your Hydraulic Motor is equipped with a Manual Override Output Shaft. The **Drill must** be capable of producing a minimum of 2000 rpm for the pump to develop appropriate pressure output.

To Retract your jack: Uni-Rotational Pump

1. Locate the Red Knurled Knob on the Directional Valve; this valve will be on the side of the manifold. Pull the Red Knob Out and Turn $\frac{1}{2}$ turn. The Knob will remain in the "Out" position. Do Not use anything other than your Fingers to manually shift the directional valve.
2. Remove the Black Plastic Cap / Silver Seal from the top of the motor. Place the drill with the Proper Size Hex Bit on the manual override shaft located at the top of the motor. Run Drill in a Clockwise Direction at 2000 rpm (minimum). The jack (s) will retract.
3. When retraction is complete, return the directional valve to the normal position. Reinstall black plastic cap / Silver Seal on motor end.

Caution: Following Manual Override Operation, Failure to Return All Valves to Normal Position may result in one or more jacks drifting down from their retracted (stowed) Position. For Directional Valves, Rotate the Red Knob Until it "Snaps" back to the Normal Position.

Note: The Normal Operating Position of the Red Knob on the Directional Valve is the "In" Position. The **Only** time the Valve should be Shifted Manually is when attempting to operate jack via Manual Override.

To Extend your jack:

1. To extend the jack, follow all of the above steps **Except Do Not** Manually Shift the Directional Valve as described in Step #3 above.

To Retract your Jack: Bi Rotational Pump

1. Remove the Black Plastic Cap / Silver Seal (foil) from the end of the motor.
2. Insert drill (capable of minimum 2000rpm) and Hex Key, 1/4 " (6mm) Allen Drive Hex Key or 7/16 " (11mm) Hex Head Socket into motor. Rotate Counter-Clockwise.

To Extend your Jack:

1. Operate the Drill in Clockwise Rotation.

Problem Solving

“The jack runs for a few seconds, then stops”

Your battery is weak or battery capacity is diminished. Charge the battery fully. It may be necessary to “load test” the battery.

“The jack only runs in one direction”

Verify appropriate battery voltage. Verify that all wires are attached appropriately. For the MTE style pump, the jack will only run in the extend direction if the battery does not have enough capacity to operate the motor and shift the directional valve.

“I push the switch and nothing happens”

Ensure both positive and negative 12V have adequate connection. Ensure full charge on your battery. 9 out of 10 calls we receive are related to a discharged battery. Ensure that the battery is grounded to the trailer chassis with a minimum #4 gauge wire. Check all associated wiring.

“The jack is jerky when retracting”

This may be caused by air in the system, low fluid level or incorrect hose installation. To purge jack, add fluid as necessary and run the jack to full extension and retraction at least twice. If problem persists, call Equalizer Systems for assistance.

Avoid Headaches Always Ensure & Verify Proper Charge on the Batteries!

Proper and Adequate Grounding of the Pump is Essential!

90% of the phone calls we receive are found to be a Discharged Batteries or Poor Grounds!

**If your problem is not listed or persists, call Equalizer Systems at 1-800-846-9659.
Please Gain Prior Authorization for Warranty Service or Repair.**

Assembly Wiring, Pump #'s 2390, 2532

Solenoid Wiring Bi-Rot Pump #'s 2390, 2532, 2542

BIROTATIONAL WIRING CONFIGURATION

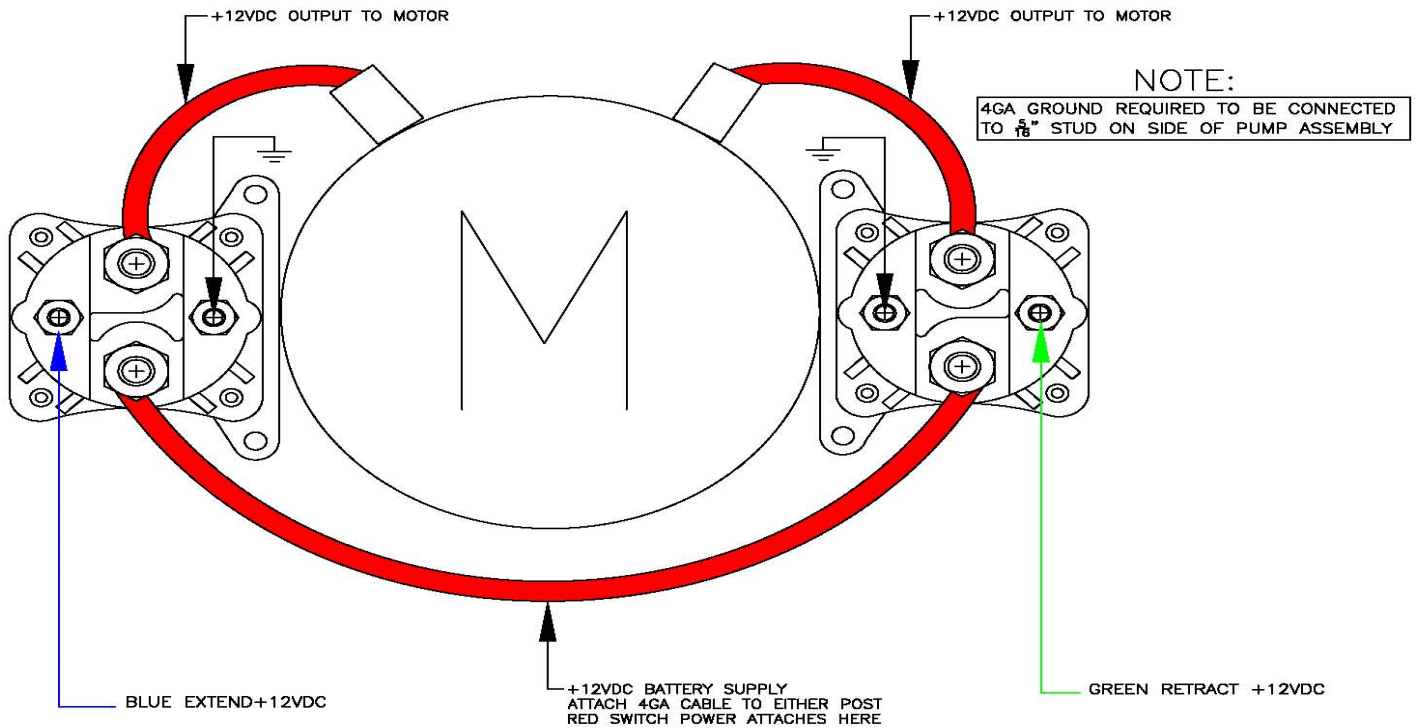

Wiring for Pump # 3043

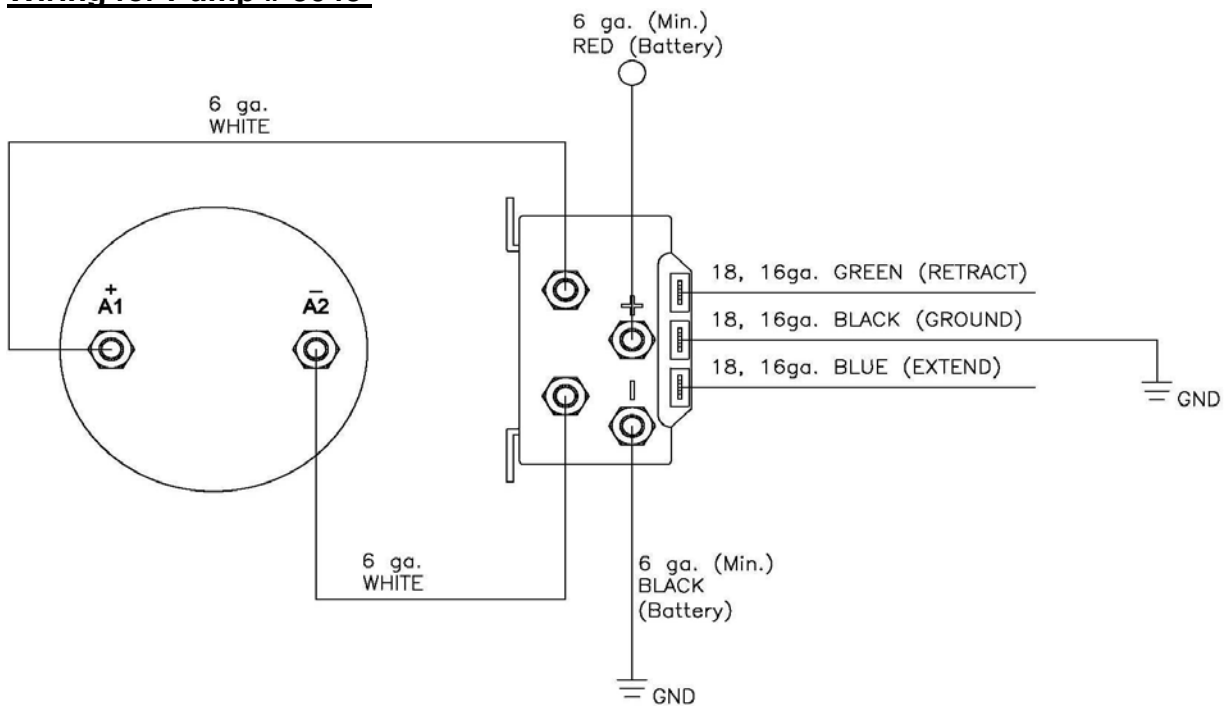



Equalizer Systems Limited Warranty Policy

RV or Vehicle Manufacturer Installed Systems or Components:

1. Only warranty claims with prior written or verbal authorization from Equalizer Systems will be recognized, all other claims will be denied.
2. Equalizer Systems warrants slide out and leveling system components for a period of **two years** from the date of original sale of the vehicle. This warranty covers defects in material and workmanship only. Equalizer Systems is not liable for any damage due to abuse, neglect, misuse, negligence, misapplication, error of operation, accidental or purposeful damage or damage due to an "act of God" such as, wind or rain damage, flood, lightning or other natural occurrence of the like. Equalizer Systems limited warranty is applicable to the Equalizer Systems components only and does not apply to the vehicle, apparatus or property to which it is attached. Warranty parts will be shipped at no charge if the repair is authorized by an Equalizer Systems representative. Purchased components used in authorized warranty repairs will be reimbursed at the original purchase price.
3. Labor and freight expenses due to warrantable parts defects or workmanship will be reimbursed for a period of one year from the date of original sale of the vehicle. Freight expenses will either be prepaid by Equalizer Systems or reimbursed at the UPS Ground rate only. Any additional shipping charges or requirements are the obligation of the vehicle owner or service center performing the warranty repair. The owner or service center's obligation may include overseas shipping charges, border fees, brokerage fees and any other additional fee of the like.
4. Warranty labor will be reimbursed only for claims that have prior written or verbal authorization from an Equalizer Systems representative. Warranty labor compensation is required to correspond with the "Warranty Parts Replacement Time Guideline" published by Equalizer Systems. Any warranty repair not listed on this guideline will require prior authorization from an Equalizer Systems representative. A reasonable time allowance will be determined by the Equalizer Systems representative. Any warranty repair that is not listed on this guideline that is performed without prior authorization will be denied without exception. Time associated with learning about the repair or excessive diagnostic and installation time will not be reimbursed. Warranty labor will be reimbursed at the authorized service center's published shop rate if the rate is reasonable for that region. Overtime labor will not be reimbursed without exception.
5. Labor, parts and freight credit (if applicable) will be sent after the parts are tested and the warranty claim is validated. Returned parts that are found to be in normal operating condition are not warrantable and will be charged to the owner or service center. Equalizer Systems reserves the right to charge back the service center for labor claim payments previously submitted if the installation of the warranted part is found to be inadequate at a later date.
6. Claims will be denied if the date submitted is greater than 30 days from the repair date.
7. Prior authorization is required before parts may be sent back to Equalizer Systems. A Return Authorization Number is required for items to be accepted.
8. Complete systems are not warranted unless authorized by an Equalizer Systems representative. There are absolutely no exceptions to this clause.
9. Consideration should be taken regarding the location and protection of Equalizer Systems' components prior to installation. Please reference our installation manuals for recommended locations and maintenance, or visit www.equalizersystems.com for more information. The failure of any Equalizer Systems' component due to extreme environmental conditions, improper installation, or lack of maintenance will not be covered under warranty.
10. Warranty coverage for parts or systems sold by non-authorized resellers (such as live or internet auctions) will be at the discretion

of Equalizer Systems.

Warranty Policy, Continued

11. This warranty begins upon the original sale date of the vehicle and is transferable, with limitation, to subsequent owners upon furnishing the original sale date of the vehicle and proof of purchase. Only the remainder of the two year parts warranty is applicable. Warranty labor and freight are only applicable to original owner of the vehicle.
12. Equalizer Systems is not liable for loss of time, manufacturing costs, labor, material, loss of profits, direct or indirect damages incurred by the vehicle manufacturer.
13. Excessive warranty labor resulting from inadequate access to the Equalizer Systems product will not be reimbursed.
14. Equalizer Systems will not pay a markup on warranty parts unless required by law.
15. Travel expenses, hotel, telephone, fuel or any other expenses of the like are not covered under warranty.

Replacement Parts:

1. Replacement parts are warranted under the same guidelines listed above for the remainder of the original warranty or 90 days, whichever is longer. Proof of warranty repair date and original vehicle purchase date are required.

No additional warranties, expressed or implied, are authorized by Equalizer Systems

This warranty voids all previous issues. Questions concerning this warranty should be directed to:

Equalizer Systems

P.O. Box 668
Elkhart, IN 46515
(800) 846-9659
(574) 266-6083 fax

1-800-846-9659 www.equalizersystems.com